



Cooperative Extension Service  
Institute of Food and Agricultural Sciences

## Control of Roof Rats in Fruit Trees<sup>1</sup>

William H. Kern, Jr.<sup>2</sup>

*This document examines the damage done by roof rats and ways of dealing with the damage they cause.*

### Background

The roof rat (*Rattus rattus*, a.k.a. citrus rat, fruit rat, black rat, or gray rat) is an introduced species of rat native to southern Asia. It was brought to America on the first ships to reach the New World and has spread around the world. This rat is the same species that carried the bubonic plague around the world and is also the reservoir host for murine typhus. Roof rats are the worst rodent pest in the state of Florida and most abundant. The Norway rat (*Rattus norvegicus*) that is familiar to most people is rare in Florida.

Roof rats consume and destroy stored animal and human food, attack fruit crops, and take up residence in attics, soffits, hollow walls, and out-buildings. When they invade buildings they chew through wires (potentially starting fires), gnaw through plastic and lead water pipes, make holes in walls and cause other structural damage.

The secretive, nocturnal nature of rats means that they often go unnoticed in a neighborhood until dooryard citrus and other fruit starts to ripen. They then

make their presence known with a vengeance. In citrus, papaya, cantaloupe and watermelon, the characteristic damage is a circular hole about the size of a quarter or half dollar and the whole fruit hollowed out (Figure 1).



**Figure 1.** Typical roof rat damage to citrus.

As we progress through the citrus season (from September through March), the roof rats that may have been living quietly around your house or grove make

1. This document is SS-WEC-120, one of a series of the Cooperative Urban Wildlife Program, a cooperative effort between the Florida Cooperative Extension Service, Institute of Food and Agricultural Sciences, University of Florida and the Florida Game and Fresh Water Fish Commission's Nongame Wildlife Program. Publication date: December, 1996. Reviewed: January, 1997. Please visit the FAIRS Website at <http://hammock.ifas.ufl.edu>
2. William H. Kern, Jr., Ph.D., urban wildlife specialist, Department of Wildlife Ecology and Conservation, Pinellas County, Largo, FL, Cooperative Extension Service, Institute of Food and Agricultural Sciences, University of Florida, Gainesville, 32611.

All chemicals should be used in accordance with directions on the manufacturer's label. Use pesticides safely. Read and follow directions on the manufacturer's label. The use of trade names in this publication is solely for the purpose of providing specific information. It is not a guarantee or warranty of the products named, and does not signify that they are approved to the exclusion of others of suitable composition.

The Institute of Food and Agricultural Sciences is an equal opportunity/affirmative action employer authorized to provide research, educational information and other services only to individuals and institutions that function without regard to race, color, sex, age, handicap, or national origin. For information on obtaining other extension publications, contact your county Cooperative Extension Service office. Florida Cooperative Extension Service / Institute of Food and Agricultural Sciences / University of Florida / Christine Taylor Waddill, Dean

themselves known. Hollowed-out fruit is the most common evidence of roof rats.

In apples, peaches, tomatoes, carambolas, bananas, pineapples and mangos, large sections of fruit are eaten away. They remove whole fruits from blueberries, figs, grapes, strawberries, lichees, Surinam cherry, loquat, and dates, so the damage is less noticeable or birds are blamed for the missing fruit. In Florida, roof rats--along with our native cotton rat--destroy or damage a great deal of sugar cane every year.

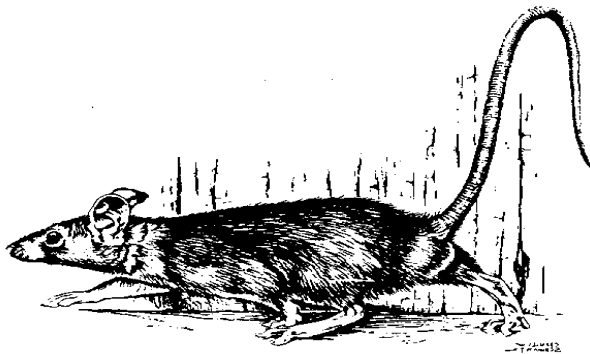

**Figure 2.** Roof rat (*Rattus rattus*)

### Description

Adult roof rats are 12-14 inches long (30-36cm) and weigh 5-10oz. (150-250g). The tail of a roof rat is longer than the head and body length: hairless, scaly, and black color. The body is sleek and graceful with prominent ears and eyes (Figure 2). There are three color phases seen in Florida: black back with a slate gray belly, gray back with lighter gray belly, and brownish gray above with a white or cream colored belly.

In addition to the damage done to fruit, other evidence includes black banana-shaped droppings about 1/4-1/2 inch long (about 1 cm) and dark smears or rub marks seen along the rat's travel routes (Figure 3).

### Range and Habitat



**Figure 3.** Evidence: rub or swing marks made by roof rats.

The roof rat occurs along the southern Atlantic and Gulf coastal States from Virginia to Texas and throughout Florida. They also occur along the Pacific coast of California, Washington state, and Oregon.

Roof rats are arboreal (tree-living) by nature. They are similar to squirrels in their ability to move through trees and along vines and wires. They often use utility lines and tree branches to reach food and water and to enter buildings. They prefer nesting above the ground in attics, soffits, piles of debris, hollow trees, skirts of old fronds on palm trees, and in Quaker parrot nests, but will nest in burrows in canal banks and under sidewalks or stacks of materials stored on the ground.

### Food

Roof rats are omnivores (plant- and animal-eating) but very fond of fruit. They feed on most cultivated fruits and eat many native fruits and nuts. They also feed on livestock feed, pet food, bird seed in feeders and garbage. They contaminate and damage much more than they actually eat. They will chew through lead and plastic pipes to reach water. They will travel 150yds. (135m.) from their den to reach food or water.

### Reproduction

Roof rats reach sexual maturity at 3 to 4 months of age. In Florida, they breed year-round, with peak breeding activity in spring and fall. The litter of 5 to 8 pups are born after a gestation period of 21 to 23 days. A female roof rat can have 4 or 5 litters per year.

### Control

Control of roof rats is not an easy task. Integrated pest management is needed to control these pests. The tools of Integrated Pest Management (IPM) include inspection; cultural control (prevention and habitat management); physical control (trapping and exclusion); biological control (predators); and--if needed--chemical control (rodenticides and repellents).

## Prevention

Because roof rats are such good climbers and swimmers it is hard to completely exclude them from your yard, grove, or orchard. Here are some cultural techniques to help you reduce damage.

### *Proper spacing and pruning of fruit trees*

Your fruit trees should be isolated, not touching fences, overhead wires, or the branches of other trees. Roof rats will run along fence stringer boards or support poles, phone and cable TV wires, and tree branches to reach your fruit tree. Lower branches of the tree should not touch the ground. A low-hanging skirt of drooping branches give the rats additional access routes and provides them with protective cover while feeding. Prune trees so that the ground under them is open and visible. This lack of cover makes the rats uncomfortable and more susceptible to predators.

Rat guards on the trunks will keep the rats out of trees (Figure 4). Rat guards can be as simple as a piece of sheet metal 18-24 inches wide and as long as the circumference of the tree plus two inches. Use a piece of wire bent like a giant staple to secure the ends of the sheet metal without penetrating the tree. Put the back of the wire against the tree's trunk and insert the two ends of the wire through holes in the sheet metal. Then bend the wire outward to hold the ends of the rat guard together. If your tree has a short or forked trunk, then a sheet metal wall, 2 feet tall (60 cm), around the tree will reduce rodent access to it. If wires go through the crown of the tree or your tree touches a fence or branches of another tree, then rat guards are useless--the tree must be

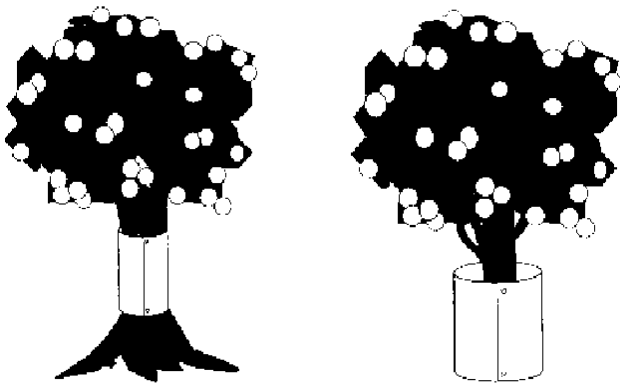

**Figure 4 .** Rat guard, rodent exclusion wall around fruit tree.

isolated for rat guards to work. Sanitation is also important. Use or remove all fallen fruit.

If you have more fruit than you can use, contact your local food banks or become involved with community fruit salvage operations.

### *Trapping*

Trapping rats has many advantages over the use of poisons. It greatly reduces the risk of the poisoned rat finding its way into your home or buildings, dying and causing an odor problem.

The tree can also be protected by tying several rat traps around the trunk of the tree with the triggers pointing down. Use expanded trigger rat traps on trees and fences. Be sure to tie the traps securely to the trunk before trying to set the traps. The next time a rat tries to climb the tree it will get caught and killed or at least given a good scare. **Set rat traps only from dusk to dawn to avoid accidentally killing non-target species like squirrels and protected birds**, such as wrens, woodpeckers, chickadees, etc. These animals are diurnal (active during the day) while rats are nocturnal (active during the night).

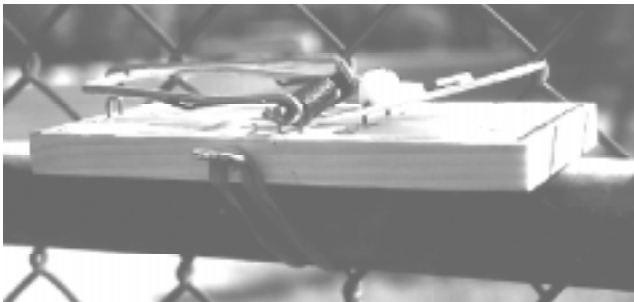

**Figure 5a.** Expanded trigger trap with protective board.

Since rats prefer to stay off the ground, they like to run along the stringer boards of fences and the horizontal support poles of chain link fences. Traps can be nailed directly to the horizontal stringer board of wooden fences. Place a protective board above the trap to discourage birds from accidentally getting in the trap (Figure 5a).



**Figure 5b.** View of a trigger trap on the horizontal pipe on a chain-link fence.



**Figure 5c.** View of another trigger trap on the horizontal pipe on a chain-link fence.

To secure rat traps to horizontal poles of chain link fences, put an eye screw on each side of the trap and use several heavy rubber bands to hold the trap to the pole (Figure 5b) and (Figure 5c). As stated before, **traps should be set only from dusk until dawn to avoid killing non-target animals active during the day.** Use of live traps will also prevent the accidental killing of birds and squirrels.

Roof rats are nervous and cautious of new objects in their environment, so leave traps in the same location for at least a week before moving them.

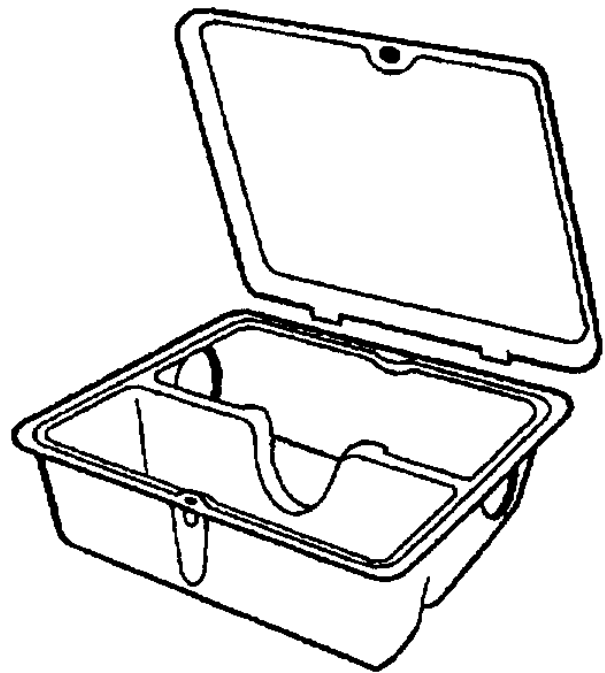

**Figure 6.** Commercially available tamper-proof or -resistant bait station.

### *Use of Poisons*

If poison baits are used outdoors, they must be placed in a tamper-resistant bait station. All rodenticide labels in Florida state that it is illegal to place any poison rodenticide baits where they are accessible to children, pets, livestock, or wildlife, unless the bait is contained in a secured, tamper-resistant bait station (Figure 6) .

The practice of wiring poison bait blocks to branches of trees is illegal and has caused thousands of cases of accidental poisoning of dogs and wildlife each year. Tamper-resistant bait stations like those in Figure 6 are not usually found in retail stores. Try pest control companies which may sell them or can refer you to another source to order them.

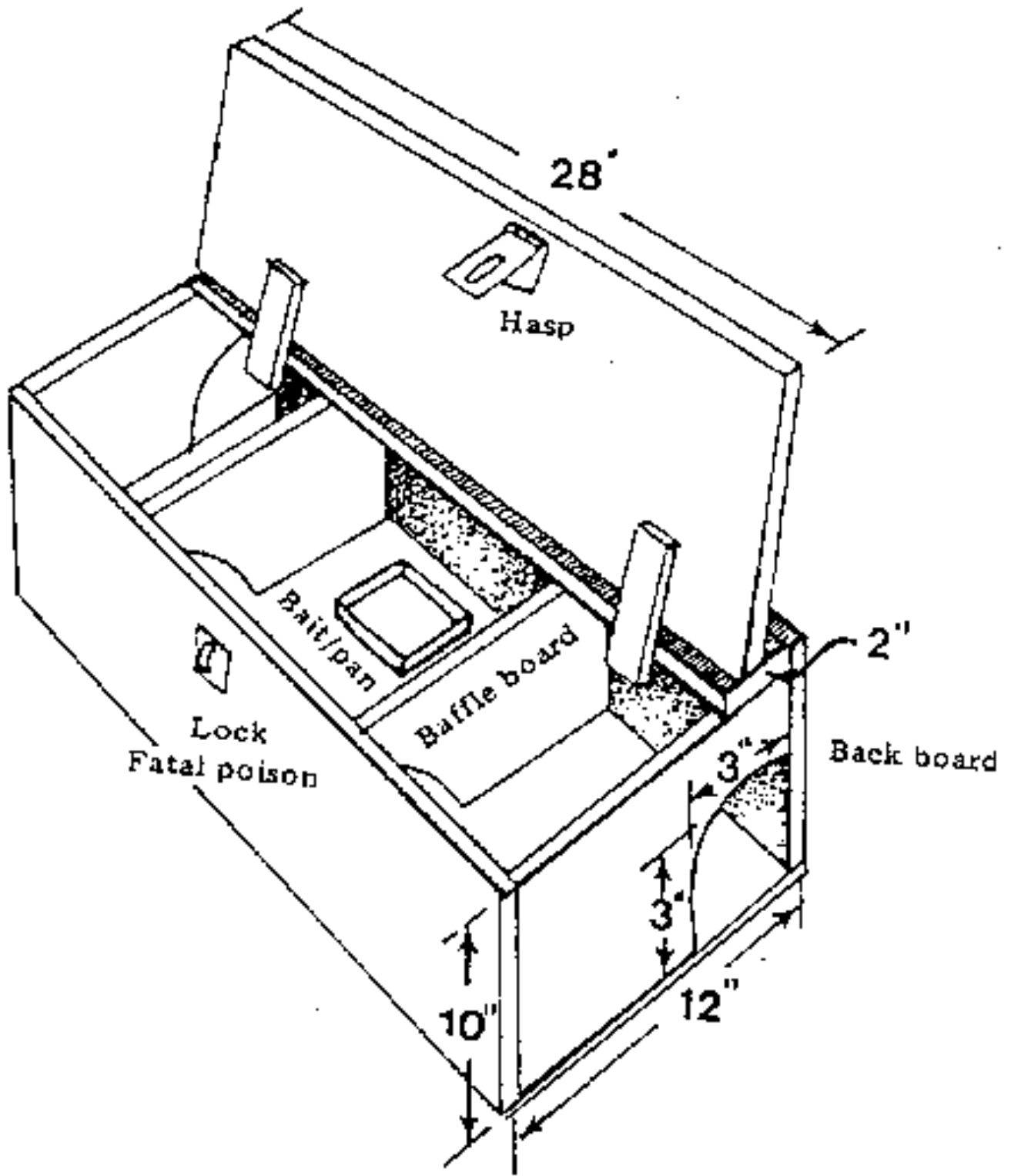

Figure 7. Plans for a do-it-yourself wooden, tamper-resistant bait station.

Plans for building an effective bait station are included in this fact sheet (Figure 7).

In Florida, due to our high humidity, parafinized bait blocks or pellets should be used in any outdoor bait stations. Some municipalities and counties have rodent control programs, but most do not. Contact your local city or county government to find out if there are programs in your area.

There are no repellents registered specifically for roof rats. Since most wildlife repellents cannot be used on human food plants, their usefulness in rat control on fruit trees is extremely limited.

### Biological and Behavioral Control: IPM

In Integrated Pest Management, we often rely on biological control agents as a cost-effective way of controlling pests. We have many allies in our war on rats.

**Snakes.** In Florida, many species of snake help control



**Figure 8.** Florida's yellow rat snake is the best ally you can have keeping rats out of your yard or grove.

roof rats. Yellow rat snakes (Figure 8), gray rat snakes, corn or red rat snakes, black racers, king snakes, coachwhips and indigo snakes all prey on roof rats. Even our venomous rattlesnakes and cottonmouths eat lots of rats.

**A Cautionary Tale.** The importance of snakes in rat control was made clear in the following report: A dog kennel worker took it upon himself to eliminate all of the snakes at his place of work. Once the rat snakes had been killed, the roof rat population exploded.

It took two years, hundreds of people-hours, and thousands of dollars to get control of the rats and repair the structural damage the rats had caused. This does not include the hundreds of pounds of dog food the rats ate and contaminated. The economic cost of removing the rats' natural predators was obvious.

**Raptors.** Hawks and owls, especially barn owls, are very effective at killing roof rats. Keeping the area around fruit trees open makes hunting easier for birds of prey.

**Cats and Dogs?** Many people believe that cats and dogs will keep rats out of their yards and fruit trees. But, because roof rats are so arboreal, they are usually able to get into attics and fruit trees without ever coming to the ground. Rats quickly learn safe travel routes through yards to avoid terrestrial predators. Cats will kill dispersing juvenile rats, but are rarely able to handle an adult roof rat within its own territory.

**Ultrasonic and Electromagnetic devices.** Many claims are made about ultrasonic and electromagnetic devices' repelling rodents from buildings and yards. There is no evidence that these devices will or can drive rodents from their home range. There *is* evidence that ultrasonic devices can cause hearing loss in pets, especially dogs.